

# TAKSTAR® 得胜



WPM-300无线监听系统 使用说明  
Wireless Monitoring System User's Manual

中文目录	2-9
前言	2
产品特性	2
适用范围	2
产品配置	3
技术参数	3
发射器参数	3
接收机参数	3
功能示意	4
主机（发射器）	4
接收器（腰包）	5
使用说明	6
对频方法	6
操作说明	6
安全警示	7
关于图标含义解释	8
关于本说明书	8
环保说明	9

## ■ 前言

尊敬的用户：

感谢您选购得胜WPM-300无线监听系统，为了您能够更好的了解使用本产品，建议您在使用前仔细阅读本说明书。

若存在有疑问或者您有宝贵的建议，可通过拨打得胜官方服务热线400 6828 333或微信扫描二维码关注得胜官方公众号与我们联系。



## ■ 产品特性

- 一款专为乐器监听、舞台监听、同声翻译等场合设计的无线监听系统；
- UHF无线传输，PLL锁相环路技术，工作稳定可靠；
- 采用复合抗干扰电路，可自动避开有干扰的频率，支持多套腰包同时使用；
- 最多可支持10台发射信号同时工作，适用于多国语言翻译的场合使用；
- 在无干扰、无障碍物的环境下使用传输距离约50米；
- 采用压缩动态扩展电路，信噪比高，确保输出声音的清晰度；
- 配套入耳式监听耳机，佩戴舒适，声音细腻饱满，低音强劲；
- 发射器具备 $\Phi$ 3.5mm音频输入接口，方便与调音台、功放等音频设备连接；

## ■ 适用范围

适用于乐器监听、舞台监听、会议监听、同声翻译等场合。

## ■ 产品配置

### WPM-300(套装)

主机 (发射器) .....	1台
副机 (接收器) .....	1个
耳塞 .....	1副
硅胶耳帽 (S、M、L) .....	3对
5号干电池 .....	2节
Φ3.5mm音频线 .....	1条
RCA音频线 .....	1条
Φ3.5mm转6.3mm插头 .....	1个
12V/300mA适配器 .....	1个
说明书 .....	1份

## ■ 技术参数

### 发射器参数

工作频率范围: 520-600MHz  
工作电流: 100mA (TYP)  
发射电源: DC12V/300mA  
发射距离: ≥50m(空旷无干扰场地)  
发射功率: 5dbm(TYP)  
发射尺寸: 159×79.8×21.1mm  
发射重量: 123g

### 接收机参数

频率范围: 520-600MHz  
工作电压: DC 2.5V (2.2V-3.0V) /AA两节电池  
工作电流: 115mA(TYP)  
频率响应: 20Hz至 15 kHz (-6dB截点)  
信噪比: >60dB  
接收灵敏度: 优于8dbuv  
立体声分离度: >45dB  
接收尺寸: 169×64×30.95mm  
接收重量: 123.5g

注: 以上数据由得胜实验室测试得到, 并拥有最终解释权!

## ■ 功能示意

### 主机（发射器）：

- ①电源开关：当开关打到“|”时，表示已开机，当打到“0”时则表示关机；
- ②LED显示屏：显示当前工作频道，有“CH01-CH10”共10个频道；
- ③耳机旋钮：调整发射器的耳机接口的音量；
- ④输入接口：一个 $\phi 3.5\text{mm}$ 立体声音频输入接口，连接外部音源；一对RCA莲花音频输入接口，连接外部音源；
- ⑤SET按键：点按SET键切换频率，详见对频方法部分；
- ⑥ 3.5mm耳机输出接口：用于连接耳机监听音源输出的声音；
- ⑦ 电源接口：用于连接规格为12V/300mA的适配器给发射器供电；
- ⑧ 天线连接座：连接外置天线，增强信号接收。

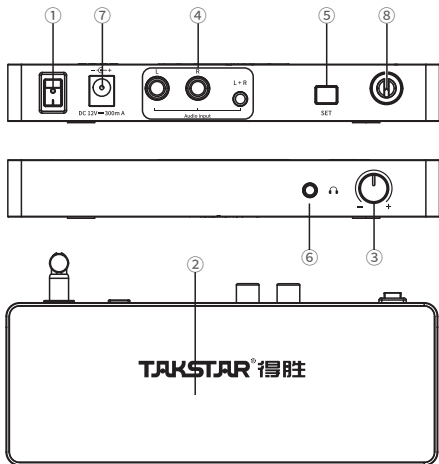

### 接收器（腰包）：

- ①电源开关：长按两秒开机/关机；
- ②指示灯：电源指示灯，正常电量时常亮绿灯，低电时常亮红灯。
- ③音量调节：接收器音量大小调节，共10档可调，点按音量“+”调大接收器音量，点按“-”调小接收器音量（默认在5档，音量调节具有记忆功能）；
- ④SET按键：点按SET键切换频率，详见对频方法部分；
- ⑤显示屏：显示当前工作频道，有“CH01-CH10”共10个频道；显示当前电池电量，三格电量；显示无线连接状态，信号图标常亮为连接成功，闪烁为信号弱，熄灭为断开连接。
- ⑥外置天线：1/4波长天线，增强信号发射距离；
- ⑦耳机接口：用于连接耳机设备进行声音监听。

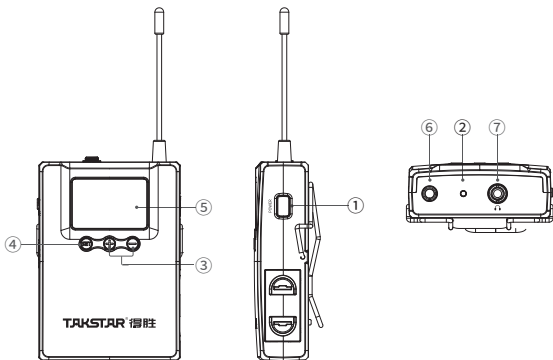

## ■ 使用说明

### 对频方法

产品出厂时已默认配对好，开机会自动连接，无需配对。如遇有信号干扰，可按下面方法进行重新配对或变频。

- 1、分别打开发射器及接收器电源开关；
- 2、点按发射器“SET”键，更换频道；
- 3、点按接收器“SET”键，更换频道，选择到与发射器显示频道一致的频道。

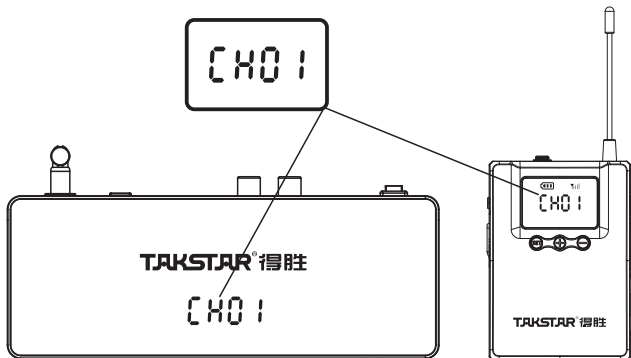

### 操作说明

- 1.将附送的适配器一端连接发射器，另一端接入市电插座，按步骤连接完成即可通电；
- 2.将转换线一端连接到发射器的音频输入接口上，另一端连接到音频输出设备上；

3. 开启发射器的电源开关，LED屏指示灯亮，表示进入正常工作状态；
4. 同时按压接收器电池仓伸缩键取出电池仓，装入两节5号电池，将电池仓推送入接收器电池卡座内，直到电池仓伸缩键“哒”的一声扣紧到位；
5. 将耳机插头插入接收器耳机插孔内；
6. 长按两秒接收器的电源开关，指示灯亮，表示接收器已进入工作状态；
7. 调节调频“SET”按键，使接收器对应发射器的频道一样，接收器屏幕信号图标常亮，即配对成功；
8. 调节接收器上的音量“-”或音量“+”按键来获得您满意的音量大小

### ■ 安全警示

为避免电击、高温、着火、辐射、爆炸、机械危险以及使用不当等可能造成的人身伤害或财产损失，使用本产品前，请仔细阅读并遵守以下事项：

1. 使用产品时请确认所连接设备与本产品功率是否匹配以及合理调整设备音量大小，不要在超过产品功率及大音量下长时间使用，以免造成产品异常；
2. 使用中若发现有异常（如冒烟、异味等），请立即关闭电源开关并拔掉电源插头，然后将产品送经销商检修；
3. 若产品需要使用可拆装电池时，严禁使用外壳绝缘材料破损的电池；请不要为非充电电池充电；
4. 废弃电池需放入指定的分类垃圾桶，不可作为儿童玩具或直接丢弃，以免造成安全隐患或影响环境；
5. 本产品及配件都应放置在室内干燥通风处，勿长期存放在潮湿、灰尘多的环境，使用中避免靠近火源，雨淋、进水、过度碰撞、抛掷、振动本机及覆盖通风孔，避免损坏其功能；
6. 使用该产品时需遵守相关安全规定，法律法规明确禁止使用场合请勿使用产品，以免导致意外事故；
7. 请不要自行拆机改装或维修，以防止出现人身伤害，如有问题或服务需求请联系当地经销商跟进处理。



### ■ 关于图标含义解释

 根据RL2004/108/EG和European Low Voltage Directive（欧洲低电压指令）RL2006/95/EG的测试结果表明，本产品符合欧共体关于电磁兼容性的成员国法律整合的指令中所规定的限值。

 未经合规方明确批准的变更或修改可能会使用户失去操作设备的权限。此设备符合FCC规则第15条部分的要求。操作须符合以下两个条件：

- (1) 此设备可能不会造成有害干扰；
- (2) 此设备必须接受接收到的任何干扰，包括可能导致意外操作的干扰。

 此符号表示，根据WEEE指令(2012/19/EU)和国家法律，由于这种类型的废弃物会有潜在的有害物质，可能对环境 and 人类健康产生负面影响，所以本产品不应与您的家庭垃圾一起处置，应将本产品交由授权的电气和电子设备（WEEE）回收站回收。同时，您在正确处理本产品的同时将有助于自然资源的有效利用。如需了解更多有关您可以在何处放置废物回收设备的信息，请联系您当地的城市办事处、废物管理局或家庭废物处理服务部门。

### ■ 关于本说明书

本说明书中内容符合截止印刷之日的技术规格。由于得胜公司会不断改进产品，本说明书可能不符合您的特定产品的技术规格。要获取最新版说明书，请访问得胜官网，然后下载说明书文件。技术规格、设备或另售的附件在各个地区可能有所不同，如有问题请与当地得胜经销商确认。如需更多支持和深层产品信息，请浏览得胜官方网站：<https://www.takstar.com/>

## ■ 环保说明

产品中所含有毒有害物质或元素的名称及含量

部件名称 (大体分类)	有毒有害物质或元素					
	铅 (Pb)	汞 (Hg)	镉 (Cd)	六价铬 (Cr(VI))	多溴联苯 (PBB)	多溴二苯醚 (PBDE)
塑胶部件	○	○	○	○	○	○
五金部件	×	○	○	○	○	○
电路板组件	×	○	○	○	○	○
线缆	×	○	○	○	○	○

本表格依据SJ/T 11364的规定编制。

○: 表示该有害物质在该部件所有均质材料中的含量均在 GB/T 26572规定的限量要求以下。

×: 表示该有害物质至少在该部件的某一均质材料中的含量超出 GB/T 26572规定的限量要求。

此标志为产品的环保使用期限标志，  
且此环保使用期限只适用于产品正常工作的温度和湿度等条件。



# WPM-300 Wireless Monitoring System

---

Contents.....	10-20
Preface.....	11
Features.....	11
Applications.....	11
Package Contents.....	12
Specifications.....	12
Transmitter Specifications.....	12
Receiver Specifications.....	12
Function Descriptions.....	13
Transmitter.....	13
Bodypack Receiver.....	14
Operation Instructions.....	16
Sync Frequency.....	16
Operation Instructions.....	17
Safety Instructions.....	18
Label Meanings.....	19
About This Manual.....	20

## ■ Preface

Dear Customer,

Thank you for purchasing Takstar WPM-300 Wireless Monitoring System. In order to better understand and use the product, please read this manual carefully. If you have any questions or suggestions, please contact our local dealer.

## ■ Features

- A wireless monitoring system tailored for instrument/stage monitoring and simultaneous interpretation.
- UHF wireless transmission, PLL (phase-locked loop) technology, stable and reliable performance.
- Anti-interference composite circuit, use multiple bodypack receivers simultaneously.
- Supports up to 10 transmitters working at the same time, suitable for multilingual interpretation.
- Transmit up to around 50 meters within line of sight.
- Dynamic companding circuit with high S/N ratio for clear audio output.
- Includes in-ear monitors that are comfortable to wear and offer rich delicate sound and strong bass.
- $\varnothing$ 3.5mm audio input on transmitter, easier to connect with mixer, amplifier or other audio device.

## ■ Applications

Suitable for instrument/stage/conference monitoring, simultaneous interpretation.

## ■ Package Contents

### WPM-300 (Set)

Transmitter	1 pc
Bodypack Receiver	1 pc
In-Ear Monitors	1 pr
Silicone Ear Tips (S, M, L)	3 prs
AA Dry Battery	2 pcs
ø3.5mm Audio Cable	1 pc
RCA Audio Cable	1 pc
ø3.5mm to 6.3mm Plug	1 pc
12V/300mA Adapter	1 pc
User Manual	1 pc

## ■ Specifications

### Transmitter Specifications

Operating Frequency: 520-600MHz
Operating Current: 100mA (TYP)
Power Supply: DC 12V/300mA
Transmitting distance: $\geq 50\text{m}$ (line of sight)
Transmitting Power: 5dbm (TYP)
Dimensions: 159×79.8×21.1mm
Weight: approx. 123g

### Receiver Specifications

Frequency Range: 520-600MHz
Operating Voltage: DC 2.5V (2.2V-3.0V) / two AA batteries
Operating Current: 115mA (TYP)
Frequency Response: 20Hz-15 kHz (-6dB intercept point)
S/N Ratio: > 60dB
Receiving Sensitivity: better than 8dbuv
Stereo Separation: >45dB
Dimensions: 169×64×30.95mm
Weight: approx. 123.5g

Note: The above data is measured by Takstar laboratory, and Takstar has the final interpretation right!

### ■ Function Descriptions

#### Transmitter:

- ① Power Switch: flip to “1” position to power on, or to “0” position to power off the device.
- ② LED Screen: displays current working channel, ranging from 10 channels, CH01 to Ch10.
- ③ Headphone Knob: adjust headphone port output volume.
- ④ Input Connector: one 3.5mm stereo audio input, for connecting external audio source; one pair of RCA audio inputs, for connecting external audio source.
- ⑤ SET Button: press SET to switch frequency, see Sync Frequency section for details.

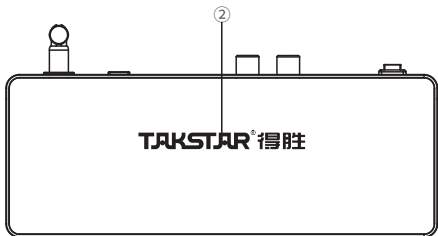

⑥ 3.5mm Headphone Output: for connecting headphones to monitor audio output.

⑦ Power Inlet: for connecting power supply via an adapter with a specification of 12V/300mA.

⑧ Antenna Connector: for connecting external antenna to enhance signal reception.

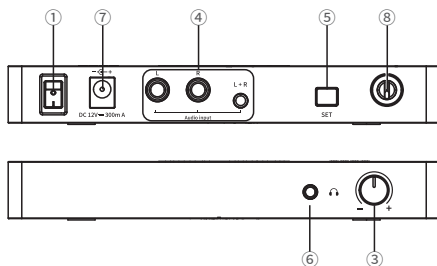

### Bodypack Receiver:

① Power Button: press and hold for 2s to power on/off.

② LED Indicator: power indicator, stays green while powered on and battery level is normal, or stays red when battery is low.

③ Volume Control: 10-step volume control; press + to increase volume, or press - to decrease. (level-5 by factory default, memorizes last volume setting)

④ SET Button: press SET to switch frequency, see Sync Frequency section for details.

## WPM-300 Wireless Monitoring System

---

⑤ LED Screen: displays current working channel, ranging from 10 channels, CH01 to Ch10.

Displays current battery level in a 3-bar meter.

Displays wireless connection status; signal indicator stays on when connected successfully, flickers during weak signal, or turns off when disconnected.

⑥ External Antenna: 1/4 wavelength antenna to enhance the signal transmission distance.

⑦ Headphone Jack: used to connect headphones for sound monitoring.

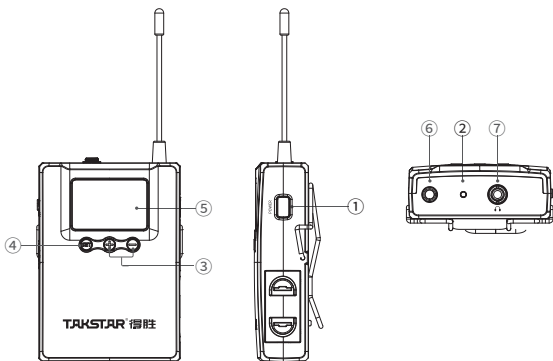



### ■ Operation Instructions

#### Sync Frequency

The transmitter and the receiver are already paired before shipping out and will auto connect to each other. Follow below re-pairing or frequency change steps only if there is signal interference.

1. Turn on transmitter and receiver.
2. Press SET on transmitter to change frequency channel.
3. Press SET on receiver to change to the same frequency channel as the transmitter.

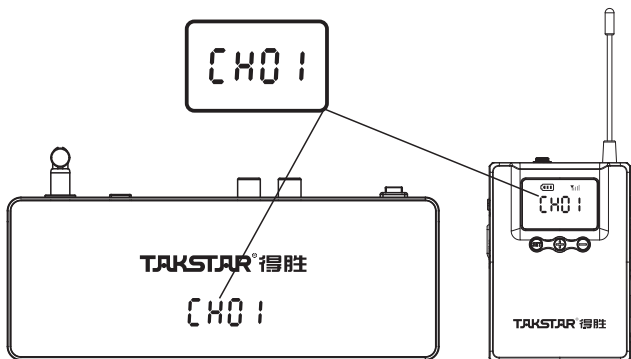

### Operation Instructions

1. Connect the transmitter to supplied adapter, plug the adapter into AC mains socket for power supply.
2. Connect the transmitter audio input with audio output device using the adapter cable.
3. Turn on the transmitter power, its LED screen and indicator lights up if working properly.
4. Pinch both the retractable buttons on the battery compartment to take out the battery holder, install 2 pieces of AA batteries, push the battery holder back into the compartment until it clicks into place.
5. Insert the headphone plug into the headphone jack on receiver.
6. Press and hold receiver power button for 2s to power up the receiver, indicated by its lit LED.
7. Press SET button to switch to the same frequency channel as the transmitter's. The receiver screen signal icon will become lit when paired successfully.
8. Press – or + button on receiver to adjust volume to a desired level.

### ■ Safety Instructions

To avoid electric shock, overheat, fire, radiation, explosion, mechanical risk and injury or property loss due to improper use, please read and observe the following items before use:

1. Please check if the power of the connected equipment matches with that of this product before operation. Adjust the volume to proper level during operation. Do not operate at over-power or high-volume level for extended time to avoid product malfunction or hearing impairment.
2. If there is any abnormality during use (e.g., smoke, strange odor), please kill the power switch and unplug from power source, then send the product to the local dealer for repair.
3. Using battery of broken insulation material is forbidden to avoid short circuit. Do not charge the non-rechargeable battery.
4. Put the waste battery into classification dustbin rather than used as toy by children or discarded directly to avoid potential danger or affecting the environment.
5. Keep this product and its accessories in a dry and ventilated area. Do not store in a humid or dusty area for extended time. Keep away from fire, rain, liquid intrusion, bumping, throwing, vibrating, or from blocking any ventilation openings, to prevent malfunction.
6. Please abide by safety rules during operation. Do not use the product in places prohibited by laws or regulations to avoid accident.
7. Do not disassemble or repair the product by yourself to avoid injury. If you have any questions or require any services, please contact our local dealer.

### ■ Label Meanings

**CE** According to the test results obtained based on RL2004/108/EG (Electromagnetic Compatibility Directive) and RL2006/95/EG (Low Voltage Directive), this product complies with the limits specified in the European Community EMC (Electromagnetic Compatibility) Directive, an integration of relevant laws from its member states.

**FCC** Note: This equipment has been tested and found to comply with the limits for a Class B digital device, pursuant to part 15 of the FCC Rules. These limits are designed to provide reasonable protection against harmful interference in a residential installation. This equipment generates, uses, and can radiate radio frequency energy and, if not installed and used in accordance with the instructions, may cause harmful interference to radio communications. However, there is no guarantee that interference will not occur in a particular installation.

If this equipment does cause harmful interference to radio or television reception, which can be determined by turning the equipment off and on, the user is encouraged to try to correct the interference by one or more of the following measures:

- Reorient or relocate the receiving antenna.
- Increase the separation between the equipment and receiver.
- Connect the equipment to an outlet on a circuit different from that to which the receiver is connected.
- Consult the dealer or an experienced radio/TV technician for help.

Changes or modifications not expressly approved by the complying party may cause the user to lose permission to operate the device.

This device complies with part 15 of the FCC Rules. Operation is subject to the following two conditions:

- 1) This device may not cause harmful interference, and
- 2) This device must accept any interference received, including interference that may cause undesired operation.

FCC ID:WRAWPM-300TX



This symbol indicates that, according to WEEE (Waste of Electrical and Electronic Equipment) Directive (2012/19/EU) and national laws, this type of waste should not be discarded along with your household waste, as it contains potentially hazardous substances that may pose a negative impact on the environment and human health. It should be handed over to an authorized WEEE collection facility for recovery and recycle. Herewith you will be helping effective utilization of natural resources. For more information on disposal of WEEE products, please contact your local municipality, waste management bureau or household waste disposal service.

### ■ About This Manual

This manual contains up-to-date technical specifications as of printing. However, specifications contained herein may not conform to your particular product since Takstar is constantly improving its products. For the latest version/more information, please visit our website: <https://www.takstar.com/>. Specifications, devices or accessories available may vary from region to region. If you have any questions, please contact our local dealer.

## 注意事项:

1. 本单为保修凭证, 请用户妥善保管, 如有遗失, 恕不保修或退换。
2. 保修期限制: 购买之日起十二个月内。
3. 除了不可抗力事件损坏外, 由本公司负责, 免费维修。
4. 如属保管不善或使用不当造成的损坏, 维修点将酌情收费。
5. 擅自拆卸维修者, 不予保修。
6. 以上保修条款仅限于中国市场适用 (不含港澳台地区)。

## 产品服务保证书

姓名: \_\_\_\_\_ 电话: \_\_\_\_\_ 地址: \_\_\_\_\_

商品: \_\_\_\_\_ 型号: \_\_\_\_\_ 购买日期: \_\_\_\_\_ 年 \_\_\_\_\_ 月 \_\_\_\_\_ 日

维修记录栏 (由维修员填写)	维修员签名	日期

◆ 广东得胜电子有限公司 ◆ 电话: 400-6828-333 ◆ 地址: 广东省惠州市博罗县龙溪街道盖康一路2号





扫一扫，了解更多产品  
Scan for more  
product information

## **广东省电声工程技术研究开发中心 广东得胜电子有限公司制造**

地址：广东省惠州市博罗县龙溪街道富康一路2号

服务热线：400 6828 333 传真：0752 6383950

邮箱：xs@takstar.com

网址：www.takstar.com

Guangdong Takstar Electronic Co., Ltd.

Address: No. 2 Fu Kang YiRd., Longxi Boluo

Huizhou, Guangdong 516121 China

Tel: 86 752 6383644 Fax: 86 752 6383952

Email: sales@takstar.com

Website: www.takstar.com